

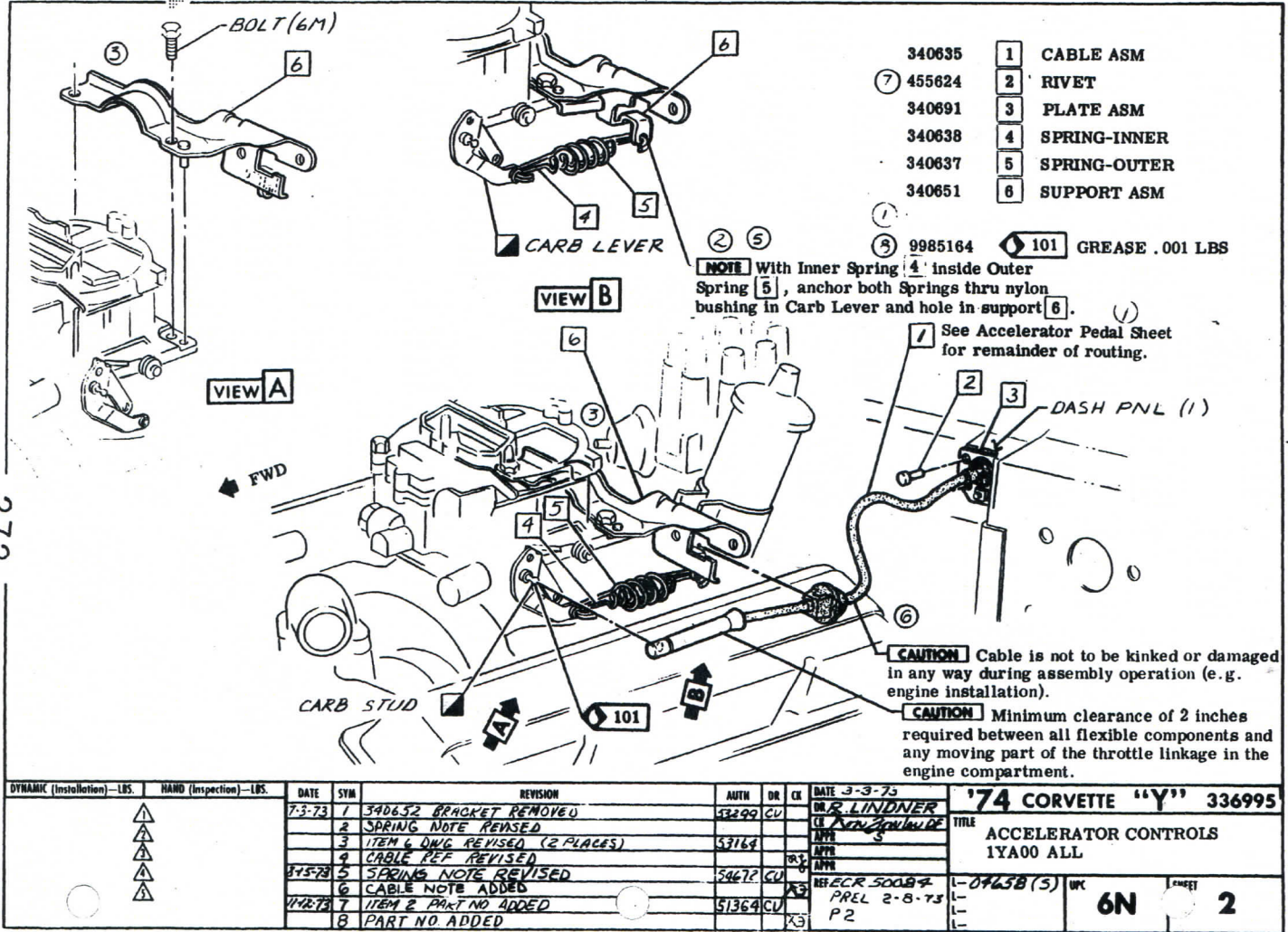

General Motors Corporation
CHEVROLET MOTOR DIVISION

PRODUCT DESCRIPTION MANUAL

□ ITEM REFERENCE ◇ PROCESS MATERIAL ▲ TORQUE ▣ PART OF OR EXISTING



- 340635 1 CABLE ASM
- 7 455624 2 RIVET
- 340691 3 PLATE ASM
- 340638 4 SPRING-INNER
- 340637 5 SPRING-OUTER
- 340651 6 SUPPORT ASM

- 9 9985164 101 GREASE .001 LBS

NOTE With Inner Spring 4 inside Outer Spring 5, anchor both Springs thru nylon bushing in Carb Lever and hole in support 6.

See Accelerator Pedal Sheet for remainder of routing.

CAUTION Cable is not to be kinked or damaged in any way during assembly operation (e.g. engine installation).

CAUTION Minimum clearance of 2 inches required between all flexible components and any moving part of the throttle linkage in the engine compartment.

DYNAMIC (Installation)—LBS.	HAND (Inspection)—LBS.	DATE	SYM	REVISION	AUTH	DR	CR	DATE 3-3-73	DR. R. LINDNER	74 CORVETTE "Y" 336995
	▲	7-3-73	1	340652 BRACKET REMOVED	53299	CV			DR. R. LINDNER	TITLE
	▲		2	SPRING NOTE REVISED					DR. R. LINDNER	ACCELERATOR CONTROLS
	▲		3	ITEM 6 DWG REVISED (2 PLACES)	53169				DR. R. LINDNER	1YA00 ALL
	▲		4	CABLE REF REVISED					DR. R. LINDNER	
	▲	8-15-73	5	SPRING NOTE REVISED	54672	CV			DR. R. LINDNER	
	▲		6	CABLE NOTE ADDED					DR. R. LINDNER	
		11-12-73	7	ITEM 2 PART NO ADDED	51364	CV			REF ECR 50087	07658(5) WPK
			8	PART NO ADDED					PREL 2-8-73	6N
									P2	2

BACK TO GENERAL INDEX

272